

Hydraulic model tests on a stormwater vortex drop shaft: Verification of special conditions

Essais hydrauliques à l'échelle réduite aux puits de chute de type vortex : Vérification des conditions spéciales

Gebhard Weiss*, Hansjoerg Brombach*, Ernst Hohl**

* Umwelt- und Fluid-Technik Dr. H. Brombach GmbH, Steinstrasse 7,
97980 Bad Mergentheim, Germany
g.weiss@uft-brombach.de

** Abwasserverband Altenrhein, Kläranlage,
CH-9423 Altenrhein, Switzerland
ernst.hohl@ava-altenrhein.ch

RÉSUMÉ

Dans certains cas, il est nécessaire de réaliser des puits de chute pour pallier de fortes hauteurs de chute dans les réseaux d'assainissement. Une solution qui a fait ses preuves consiste à créer un puits de chute à Vortex qui garantit un écoulement stable sans pulsations et coups de bélier et ce même avec de forts débits. Cependant, la complexité de construction de la forme géométrique du puits à Vortex peut s'avérer onéreuse.

A Rorschach, en Suisse au bord du lac de Constance, un nouveau puits de chute de type Vortex a été mis en service récemment. De nombreux essais de modélisation hydrauliques à échelle réduite ont permis de vérifier sa conception, sa taille et sa forme. Ces essais ont aussi démontré qu'à performance hydraulique égale, cette solution simplifiée était plus rentable que les recommandations actuelles.

ABSTRACT

In urban sewer networks, special drop structures are necessary where large stormwater flows must be guided down over high heads. Tried-and-tested solutions are vertical vortex drop shafts which are capable of draining a wide span of flows without pulsation effects. Construction details for such structures are laid down in several guidelines and standards in Switzerland and Germany. However, the usual spiral-shaped vortex chamber requires delicate moulding work and is expensive to construct.

In the city of Rorschach at Lake Constance, Switzerland, a new vortex drop shaft with simplified geometry went into operation recently. The design was verified by thorough model tests in reduced scale in the hydraulic laboratory. It appears that much easier construction work than proposed by the mentioned guidelines is possible without a reduction in hydraulic performance as predicted by comparatively cheap hydraulic model tests.

KEYWORDS

Vortex drop shaft – sewer structures – hydraulic model tests – hydraulic performance

1 INTRODUCTION

To discharge stormwater in urban drainage, it may be necessary at several locations to bridge higher level drop differences by using specific drop shaft structures, not only in mountainous regions. Systematic work on drop structures in sewers has been published by Merlein et al. (2002). A well-known and tried-and-tested drop structure solution is the spiral vortex drop shaft, see e.g. Hager and Kellenberger (1987), Kellenberger (1988), Kleinschroth and Wirth (1981). This type of structure ensures smooth and hydraulically stable flow conditions without oscillations and pulses over a wide range up to very large discharges and drop heads. Anyhow, the standard solutions which may be found in several guidelines, e.g. from Switzerland (SIA 40, 1980) and Germany DWA-A 112 (2007), require a rather delicate concrete moulding work due to the spiral-shaped vortex chamber.

In any vortex drop shaft, the arriving water is fed tangentially into the vortex chamber on top of the vertical drop shaft. There a stable vortex flow is established; the water leaves the chamber downwards by a vertical circular pipe. By centrifugal forces and Coanda effects, the water follows a helical motion at the outer wall of the shaft. Thus, an air-filled core inside the downpipe is established by which air may escape. A "wild", non-controllable entrainment of air is avoided which may form large bubbles in other drop structure types. Such bubbles tend to move upwards, opposite to the main water flow, and may give reason to "burping" and flow eruptions and oscillations. The lower end of the downpipe leads into an energy dissipation chamber.

For the design of vortex drop shafts, the cited standards offer some specimen drawings and dimensions for standard situations. In particular, it is distinguished whether the inflow to the vortex takes place at subcritical or supercritical hydraulic conditions, the former usually in sewers with mild slope, and the latter in steeply inclined pipes. Anyhow, the standard structure shape is particularly complex at supercritical inflow with spirally shaped walls while also the bottom of the vortex chamber is formed as a helical ramp (Fig. 1, right graphics).

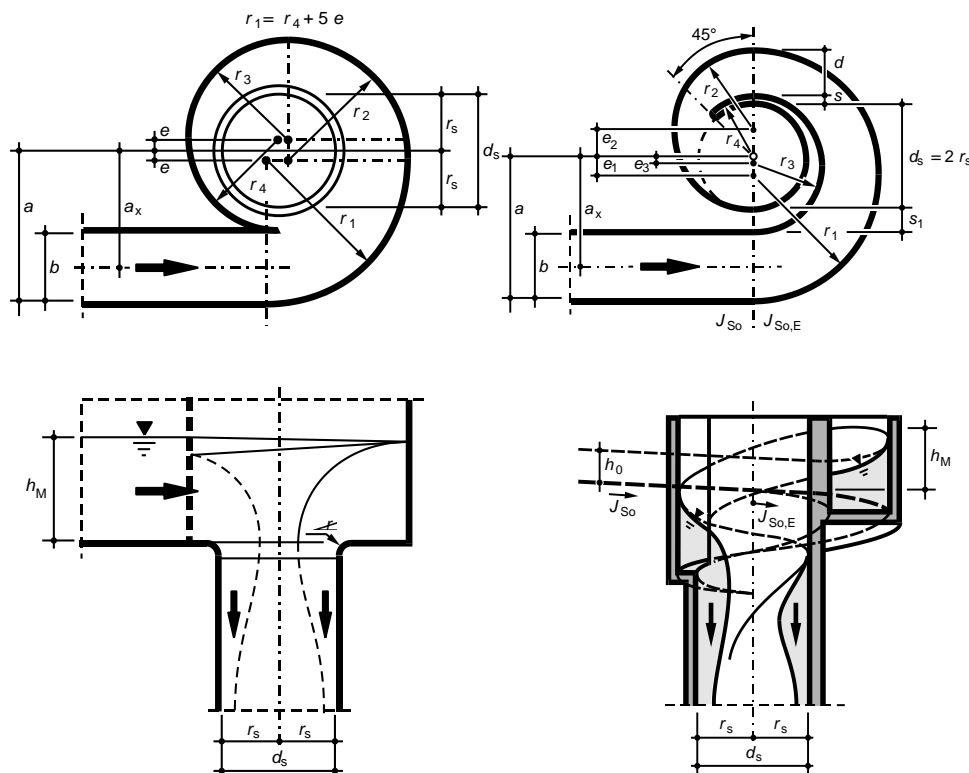

Fig. 1. Proportions of spiral vortex drop shaft chambers for subcritical inflow (left) and supercritical inflow (right), according to the German standard DWA-A 112, 2007.

In a recent project of the City of Rorschach in Switzerland, a new vortex drop shaft "Wiggen" had to be designed where these standards were not applicable for several reasons. The scope of the present paper is to show an alternative design which was verified by thorough (yet comparatively cheap) "classic" model tests in reduced scale in a hydraulic laboratory. It appears that much easier construction work than proposed by the mentioned guidelines is possible without any reduction in hydraulic performance.

2 MODEL TESTS

The City of Rorschach is situated on the south bank of Lake Constance. The Abwasserverband (sewage board) of Altenrhein is operator of a wide-stretched combined sewer network and a large central treatment plant. The city areas of Rorschacherberg and Staad are situated on the hillside slope, viewing the lake. An existing deep sewer tunnel having a length of 4.7 km is crossing underneath. This sewer has been reconverted for use as a combined sewer storage tunnel recently by adding two weir structures. Moreover, it was desired to connect the sewers from the catchment of Rorschacherberg directly to the tunnel by a new vortex drop shaft "Wiggen". The level difference is about 12 m. As a special feature, the vortex drop shaft has two feed pipes: The South inflow is a steep existing sewer, following the hill slope, while West is a mildly sloped sewer. From the South, a maximum inflow of 990 L/s and from the West, 3300 L/s are anticipated as design inflows. The total maximum future flow is about 4290 L/s. In order to avoid an extra junction chamber structure, both feed pipes open out tangentially into the vortex chamber, of course in the same sense of rotation.

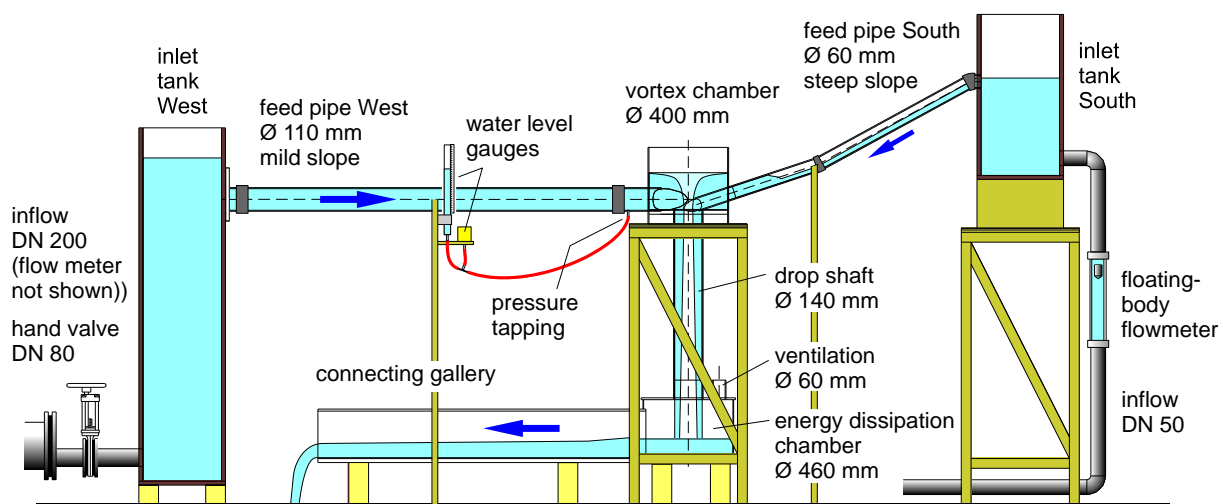

Fig. 2. Hydraulic model of the vortex drop shaft at Wiggen

This general arrangement has been described also by Volkart (1984). However, it was not possible to use standard designs for the Wiggen structure. Modern numeric CFD modelling is still delicate to apply for complex three-dimensional open-surface flows as given here. Thus, it was necessary to perform "classic" hydraulic model tests in reduced scale:

- Dimensioning and optimization of all structure components (vortex chamber, feed pipes, energy dissipation chamber)
- Determination of the maximum water levels which are expected in the feed sewers at maximum inflow
- Variation of inflows in a broad range
- If necessary, proposal of measures to limit backwater in the vortex chamber and, hence, in the feed sewers

The model size was chosen with respect to practical maintenance with a length scale of $M_L = 1:10$. Due to the Froude scaling law for open-surface flow phenomena, the flow scale was $M_Q = M_L^{2.5} =$

1:316.2. To ensure cheap construction and to avoid puzzling mould work, a circular vortex chamber with horizontal bottom was favoured. The diameter of the vortex chamber and of the downpipe were roughly pre-dimensioned according to DWA-A 112 (2007) as 4.00 m (400 mm in reduced scale) and 1.40 m (140 mm), respectively. The vortex chamber and the downpipe are arranged concentrically.

In the hydraulic model, inflows from both feed pipes were measured with an inductive flow meter plus a floating-body flow meter. The model was constructed from acrylic glass pipe sections. The inlet tanks from which both feed pipes are emerging were constructed from surface-coated waterproof plywood.



Fig. 3. The 1:10 scale model test. The second feed pipe opens out into the vortex chamber from the rear, it is not visible from this view.

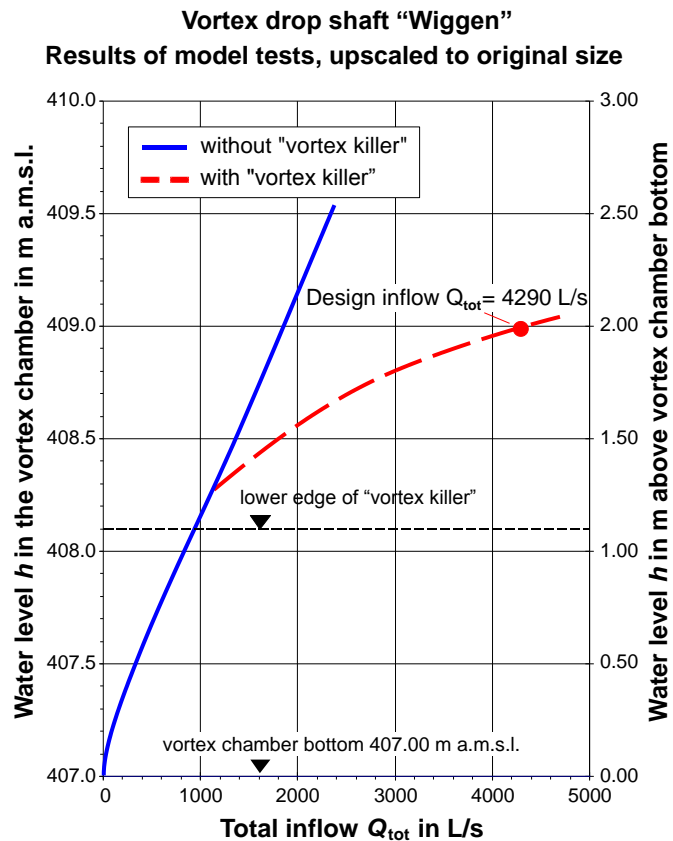

Fig. 4. Resulting hydraulic characteristics $Q(h)$ from the model tests, valid for original size

3 HYDRAULIC PERFORMANCE

The geometry of a vortex drop shaft chamber is similar to that of a vortex flow control, cf. Brombach (1972). Such devices are in common use for outlet flow control at combined sewer overflow structures and feature good flow control efficiency (i.e. a small flow at considerable head) with rather large open cross-sections which make the devices less sensitive to clogging. Early applications of vortex flow for flow control purposes go back to the 1920's, see Thoma (1928). The effect is caused by the hydrodynamic laws of vortex flow which form a bathtub-like vortex core in the centre. Research on flow control applications concentrated on maximum hydraulic resistance, i.e. minimum flow at a given cross-section. If, on the other hand, the flow is given, this results in maximum backwater upstream.

At the same time, researchers designed vortex drop shaft chambers with similar shape, notably Drioli 1947 (cited in Merlein et al. 2001). For this application, however, low upstream backwater is desired. In the classic drop shaft chamber design for subcritical inflow from Fig. 1 left, the bottom of the vortex chamber is shaped as a spiral rim with decreasing width following the perimeter, so that the incoming

water will be fed completely into the downpipe during one whole 360° turn. There is also a “bathtub funnel”, but the flow resistance is somewhat less pronounced, since this geometry forces a “loosely-wound” potential flow vortex. A circular vortex chamber shows a somewhat different pattern of flow paths: the spiral is more tightly wound and asymmetric (Fig. 5). The inflow is accelerated by being displaced to the outer chamber wall by the vortex; there is a separation streamline. Thus, the flow control effect is stronger. The fact that a drop shaft features a free-surface vortex flow while a vortex flow control usually works under pressure does not influence these basic observations.

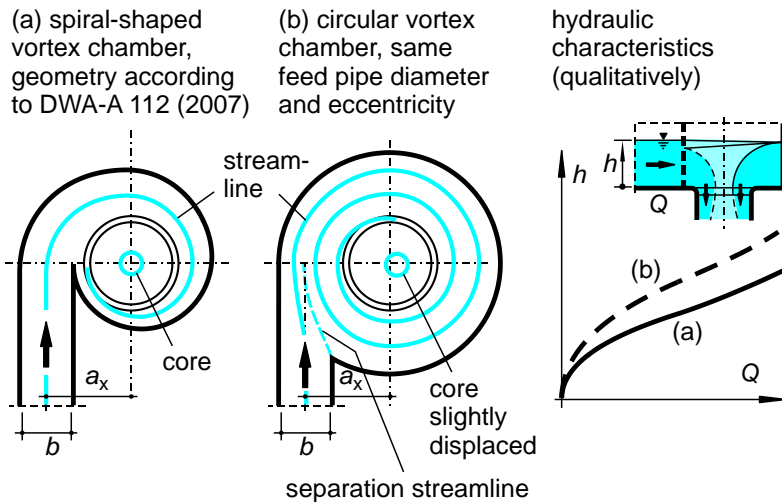

Fig. 5. Comparison of flow pattern and hydraulic characteristics between spiral-shaped (left) and circular (right) vortex chambers for subcritical inflow

The present model tests using a circular vortex chamber revealed, as expected, a rather high hydraulic resistance with very high water levels in the vortex chamber; see the solid line in Fig. 4. These levels were not acceptable and countermeasures were sought. Moreover, it could be observed by using both feed pipes alternately that the same flow yielded higher backwater when the inflow velocity was large, i.e. if the flow came from a small pipe.

From the authors' experience with vortex flow controls, it could be expected that not only a spiral shape, but also a smaller circular vortex chamber diameter would lead to somewhat smaller head losses. Anyhow, a simple circular-shaped vortex chamber with concentric downpipe was desired here for structural reasons and considering the fixed chamber diameter. Another obvious countermeasure would be to lower the vortex chamber bottom; however, alternative measures were sought after.

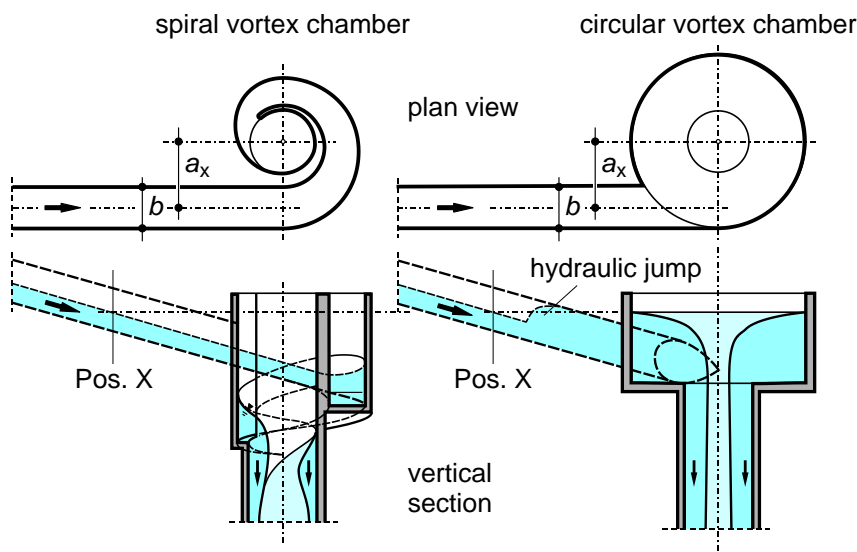

Fig. 6. Spiral and circular chambers of vortex drop shafts with a steep inflow pipe

A very effective countermeasure against a too high backpressure was finally found by using some vertical plates which are inserted in the vortex chamber. A similar proposal with a simple separation

wall is shown by Kleinschroth and Wirth (1981). We developed a "vortex killer" which consists of a cross of vertical plates with their lower edge 1100 mm (original size) above the vortex chamber bottom, see Fig. 7. In Fig. 4, hydraulic characteristics for the prototype size are shown. It was determined that the "vortex killer" allows more than double inflow with the same backwater level in the approaching sewers. For the prototype size, we designed four fold-away plates hinged at the wall. They are connected in the centre with a bolt. The plates may be disconnected and pivoted to the wall when access to the drop shaft from the top hatch is needed, e.g. for access of the deep tunnel with heavier equipment which is lowered using a crane.

This "vortex killer" may also be good for increasing the flow capacity of existing drop shaft structures since it is well-suitable for retrofitting. In any case, hydraulic model tests are recommended.

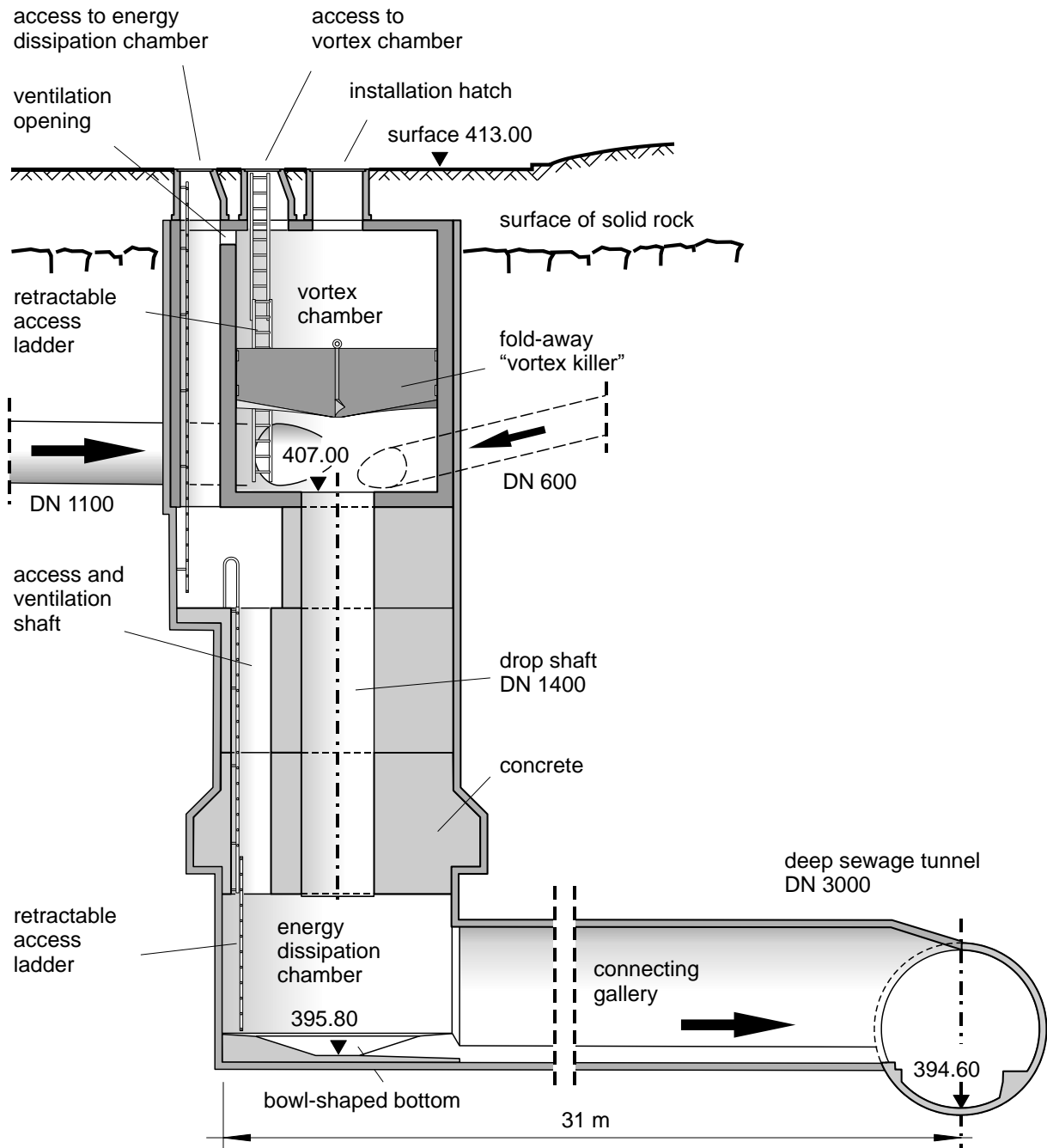

Fig. 7. Section of the Wigen vortex drop shaft structure

For vortex drop shafts where the inflow pipe is steep, the design according to DWA-A 112 (2007) guides the inflow supercritically in a spiral down to the wall of the downpipe; see Fig. 6 (left). This seems very elegant, but it is not needed in practice and it requires complex structure geometry. If a steep feed pipe opens out in a simple circular vortex chamber as in the present model tests, water will back up due to the vortex and fill up the lowermost part of the feed pipe, as shown in Fig. 6 to the right. Of course, a hydraulic jump will form upstream in the feed pipe then. However, the steep inflow pipe has sufficient level difference of several metres so that this mode of operation does not reveal any disadvantages. Upstream of Pos. X in Fig. 6, no difference will be noticeable at all. To sum it up: A spiral-shaped vortex chamber according to Fig. 6 (left) may be required in very few cases only, and a much simpler circular chamber as shown in Fig. 6 (right) will mostly be sufficient. It should be verified using hydraulic model tests.

A gently-sloping feed pipe with subcritical inflow will also run under backwater at large inflows. This must be accounted for as a downstream boundary condition when calculating the water levels in the upstream sewer system. It is generally similar to inflow pipes upstream of an overflow weir where the same backwater effect may take place. Thus, keeping backwater low is more decisive here than at steep inflow pipes. A "vortex killer", verified by model tests, may be useful even when a simple circular chamber design (Fig. 5b) is used rather than a spiral-shaped one (Fig. 5a).

Even at large inflows, the vortex flow in the hydraulic model proved to be stable, regardless of subcritical or supercritical inflow. In particular, no collapsing of the vortex or pulsating air entrainment into the drop shaft was observed. A decisive dimension is a sufficiently large drop shaft diameter which could be chosen according to the recommendations in the mentioned design standards with respect to the total design inflow.



Fig. 8. Circular water jet falling down into the energy dissipation chamber of the Wiggen drop shaft during a minor rain event. The total drop head is 11.2 metres. (Photo: Hohl)

4 DESIGN AND CONSTRUCTION

Construction work on the Wiggen vortex drop shaft started in 2007. The structure was completed within 10 months and went into operation in autumn 2008 (Fig. 8). Construction in the solid rock revealed no particular difficulties. After excavating the shaft, the glassfiber-resin downpipe was

inserted and mantled with concrete. There is also a parallel access and ventilation shaft equipped with ladders which allows safe access even during minor storm events. At the top end, the ventilation shaft is connected to the vortex chamber by a ventilation hatch. Thus, entrained air may exchange without excessive blowing through the manhole covers. The “vortex killer” is not yet installed because only a small part of the catchment is connected already. The device can be retrofitted when needed later.

The bowled shape of the bottom in the energy dissipation chamber was also optimized in the model tests. Even at small flows, there is always a “water cushion” and the water pouring down does not hit directly the concrete floor.

5 CONCLUSIONS

Swiss and German guidelines for stormwater vortex drop shafts recommend spiral-shaped structures which are rather difficult to construct. In the presented project, it could be shown that a simple and cheap-to-construct circular vortex drop shaft chamber design is applicable even under less favourable hydraulic conditions, notably for two feed pipes of different slope, flow and diameter. Model tests in reduced scale (1:10) were performed in the hydraulic laboratory to verify the design, size and shape of the structure. As a particular feature, a new “vortex killer” device was invented which reduced the water levels in the approaching sewers during extremely high flows considerably and which may also be applied in other vortex drop shaft projects for rehabilitation.

The model tests yielded the desired data on the upstream water levels which are to be expected under various operation conditions with sufficient accuracy. Even if today numerical CFD flow computations are used widespread, classic hydraulic model tests are still a good and also cost-effective means for sound engineering. The structure is under operation since 2008 and shows good performance.

LIST OF REFERENCES

- Brombach, H. (1972): *Untersuchung strömungsmechanischer Elemente (Fluidik) und die Möglichkeit der Anwendung von Wirbelkammerelementen im Wasserbau*. Universität Stuttgart, Institut für Wasserbau, Mitteilungen, Heft 25
- DWA-A 112 (2007): *Hydraulische Dimensionierung und Leistungsnachweis von Sonderbauwerken in Abwasserkanälen und -leitungen*. Arbeitsblatt, DWA-Regelwerk. Hennef: Deutsche Vereinigung für Wasserwirtschaft, Abwasser und Abfall e.V.
- Hager, W.H., Kellenberger, M. (1987): *Die Dimensionierung des Wirbelfallschachtes*. gwf Wasser – Abwasser 128, Heft 11, S. 582-590
- Kellenberger, M. (1988): *Wirbelfallschächte in der Kanalisationstechnik*. Zürich, Mitteilungen der Versuchsanstalt für Wasserbau, Hydrologie und Glaziologie, ETHZ, Nr. 98
- Kleinschroth, A., Wirth, H. (1981): *Dimensionierung von Wirbelfallschächten unter Berücksichtigung verschiedener Zuflussbedingungen*. Hydraulik und Gewässerkunde, Technische Universität München, Mitteilungen, Heft Nr. 36
- Merlein, J., Kleinschroth, A., Valentin, F. (2002): *Systematisierung von Absturzbauwerken*. Hydraulik und Gewässerkunde, Technische Universität München, Mitteilungen, Heft Nr. 69
- SIA 40 (1980): *Sonderbauwerke der Kanalisationstechnik. Hydraulische Berechnungsgrundlagen und konstruktive Hinweise*. SIA-Dokumentation 40. Schweizer Ingenieur- und Architekten-Verein
- Thoma, D. (1928): *Vorrichtung zur Behinderung des Rückströmens*. Reichspatentamt, Patentschrift Nr. 507713, 12.06.1928
- Volkart, P. (1984): *Der Wirbelfallschacht als Vereinigungsbauwerk*. Zürich, Mitteilungen der Versuchsanstalt für Wasserbau, Hydrologie und Glaziologie, ETHZ, Nr. 69